



BALDOR® • RELIANCE

Part Information Packet

KAMAN INDUSTRIAL TECHNOLOGIES

ZDFRPM21204C

20HP, 1750RPM, 3PH, 60HZ, 2162C, TEFC, FOOT

Part Detail			
Model Number:	ZDFRPM21204C	Environment:	General Purpose
Voltage:	460	HP:	20
RPM:	1775/3545	Efficiency:	NA
Phase:	3	Frequency:	N/A
Inverter Duty:	Y	Enclosure:	TEFC
Frame Group:	210	Frame Size:	FL2162CZ
Features:	RPM AC	Mounting:	Foot Mounted
Service Factor:	1	Enclosure Group:	TEFC
List Price:	5653.00	Price Symbol:	E2
Speed Range:	1201-1800	Insulation Class:	H
Nema Design:		Encl. Enhancement:	
Catalog Page:	B-196	Dimension Sheet:	617517-23
Connection Diagram:	422927-1	Electric Design:	L3308A
Single HP:	20	Get Notes:	RPM AC
Revision:		Instruction Manual:	
Application:	Variable Speed-V*S	Epact:	
Scaled Drawing:		Obsolete:	N
Last Data Source:	RGG,MADD	Bearing Type:	
Electrical Type:		Mounting Pos.:	
Ambient:	40	Duty:	
Amps:		Nominal Eff.:	
Kva Code:		Power Factor:	
Poles:	00	Weight:	0

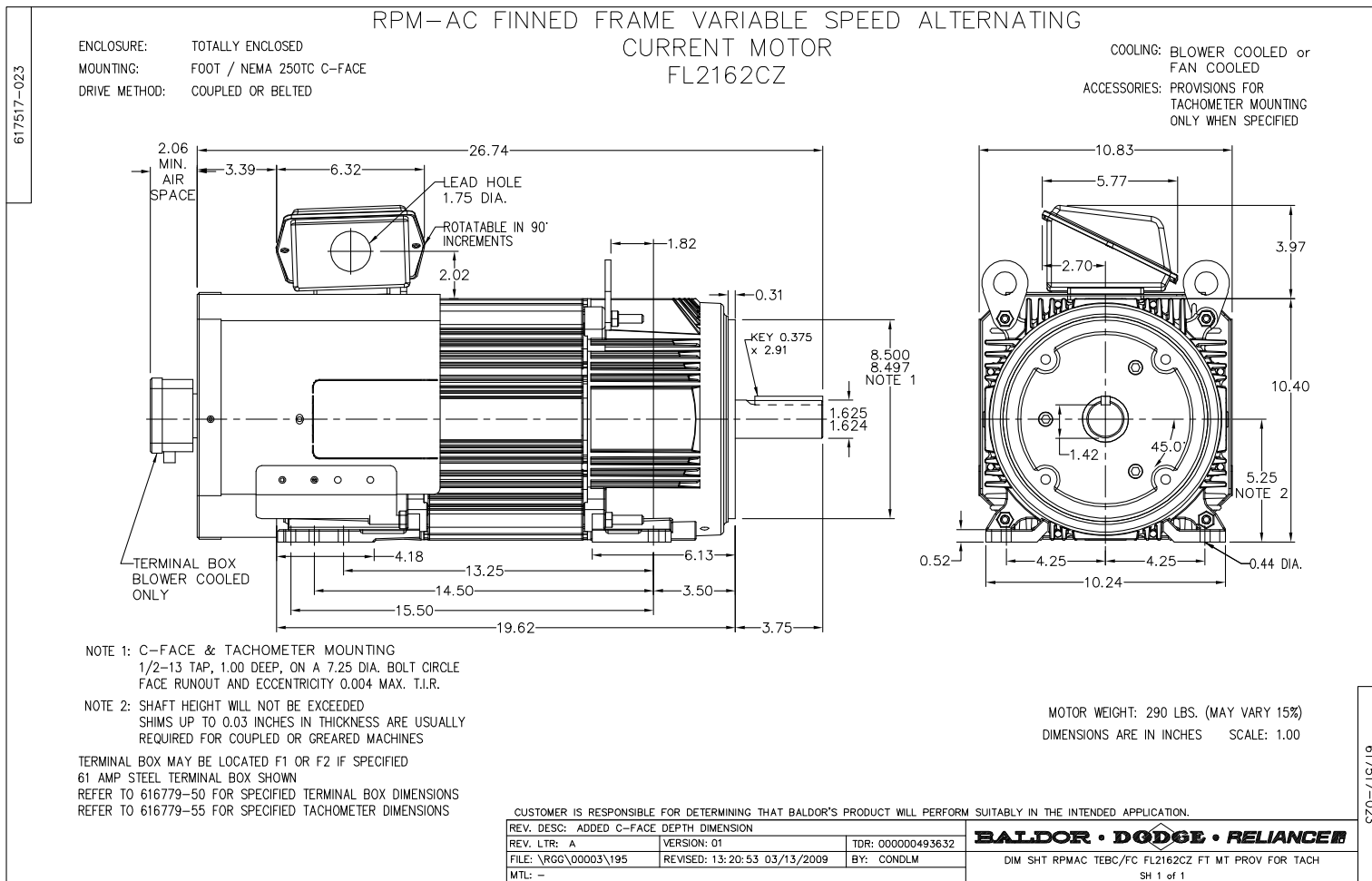

422927-001

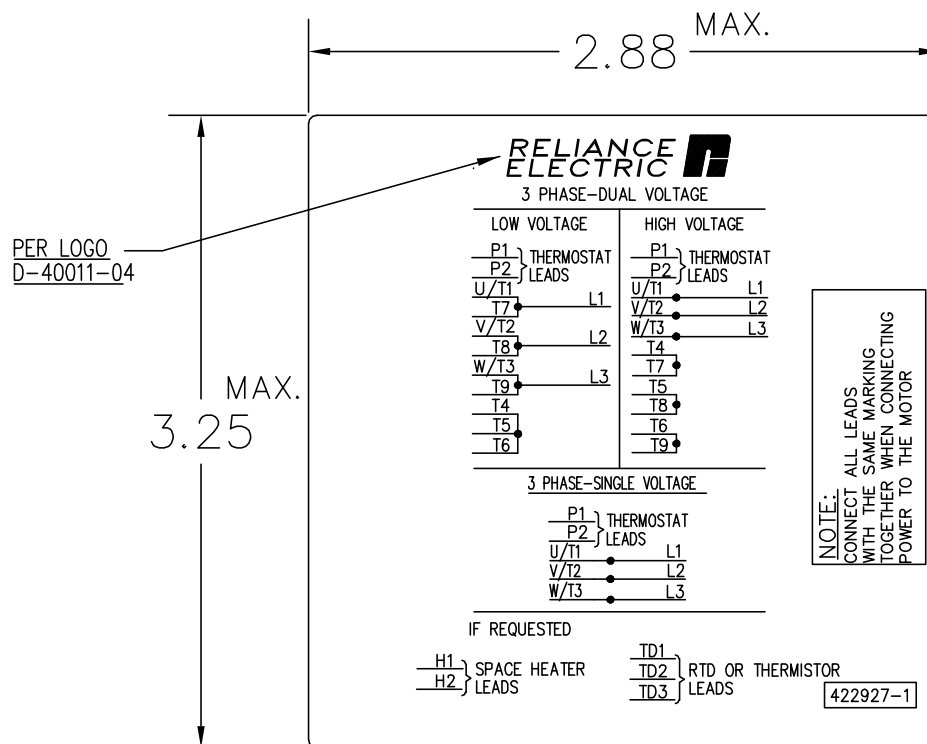

NOTE:
DATA TO BE SIZED SO THAT IT FITS INTO MATERIAL DECAL DIMENSIONS. MAKE LETTERS & NUMBERS AS LARGE AS POSSIBLE.

MATERIAL: CERAMATIC DGF-P4
PERMA GRIP ADHESIVE

ALL LETTERS, NUMBERS AND LINES TO BE BLACK ON GOLD BACKGROUND.

422927-1

422927-001

REV. DESC: LOADED TO BUS		
REV. LTR: -	VERSION: 00	TDR: 000000453444
422927-001	FILE: \RGG\00000\203	REVISED: 13:36:39 01/17/2008
	MTL: -	BY: CONBPM

BALDOR • DODGE • RELIANCE

EXTERNAL CONNECTION LABEL

BALDOR • RELIANCE Part Information Packet: ZDFRPM21204C - 20HP, 1750RPM, 3PH, 60HZ, 2162C, TEFC, FOOT

REL S.O.	-	VOLTS	460	ENCLOSURE	TEFC	WYE CONN EQ CKT OHMS PER PHASE		
FRAME	FL2162	AMPS	27	MAX SAFE RPM	5000	(AT BASE RATING, 25 °C)		
HP	20	DUTY	CONT	IM (AMPS)	15	R1	.179 X1 .845	
BASE SPEED	1775	S.F.	1.0	P.F.@NL/FL	.066/.777	R2	.122 X2 1.09	
PHASE/HERTZ	3/60	AMB °C/INSUL	40/H	WK ² (Lb-Ft ²)	1.92		XM 18.1	
RATED FULL LOAD DATA								
	RPM	HP	TORQUE LB-FT	FUND VOLTS	FREQ-HZ	AMPS		
BASE SPEED	1774	20.0	59	460	60	26.9		
MAX SPEED	3543	20.0	30	460	120	24.4		
MIN SPEED	0	0	59	13.8	.874	26.9		
LOAD PERFORMANCE AT BASE SPEED								
	RPM	HP	TORQUE LB-FT	FUND VOLTS	FREQ-HZ	AMPS		
NO LOAD	1800	0	0	460	60	14.4		
1/4	1794	5.01	15	460	60	15.7		
1/2	1787	10.0	29	460	60	18.6		
3/4	1781	15.0	44	460	60	22.4		
FULL LOAD	1774	20.0	59	460	60	26.9		
O/L	1742	39.3	119	460	60	48.5		
BLOWER DATA								
	VOLTS	PH/HZ	FL AMPS	LR AMPS	FRAME	CFM		
REMARKS: TYPICAL DATA CORRELATED DATA								
BALDOR BALDOR • DODGE • RELIANCE				DR. BY B. GRANT CK. BY B. GRANT APP. BY T. CUFR DATE 6-6-06	A-C MOTOR PERFORMANCE L3308A DATA ISSUE DATE 6-6-06			

REL S.O.	-	VOLTS	460	ENCLOSURE	TEFC	WYE CONN EQ CKT OHMS PER PHASE	
FRAME	FL2162	AMPS	27	MAX SAFE RPM	5000	(AT BASE RATING, 25 °C)	
HP	20	DUTY	CONT	IM (AMPS)	15	R1	.179 X1 .845
BASE SPEED	1775	S.F.	1.0	P.F.@NL/FL	.066/.777	R2	.122 X2 1.09
PHASE/HERTZ	3/60	AMB °C/INSUL	40/H	WK ² (Lb-Ft ²)	1.92	XM 18.1	

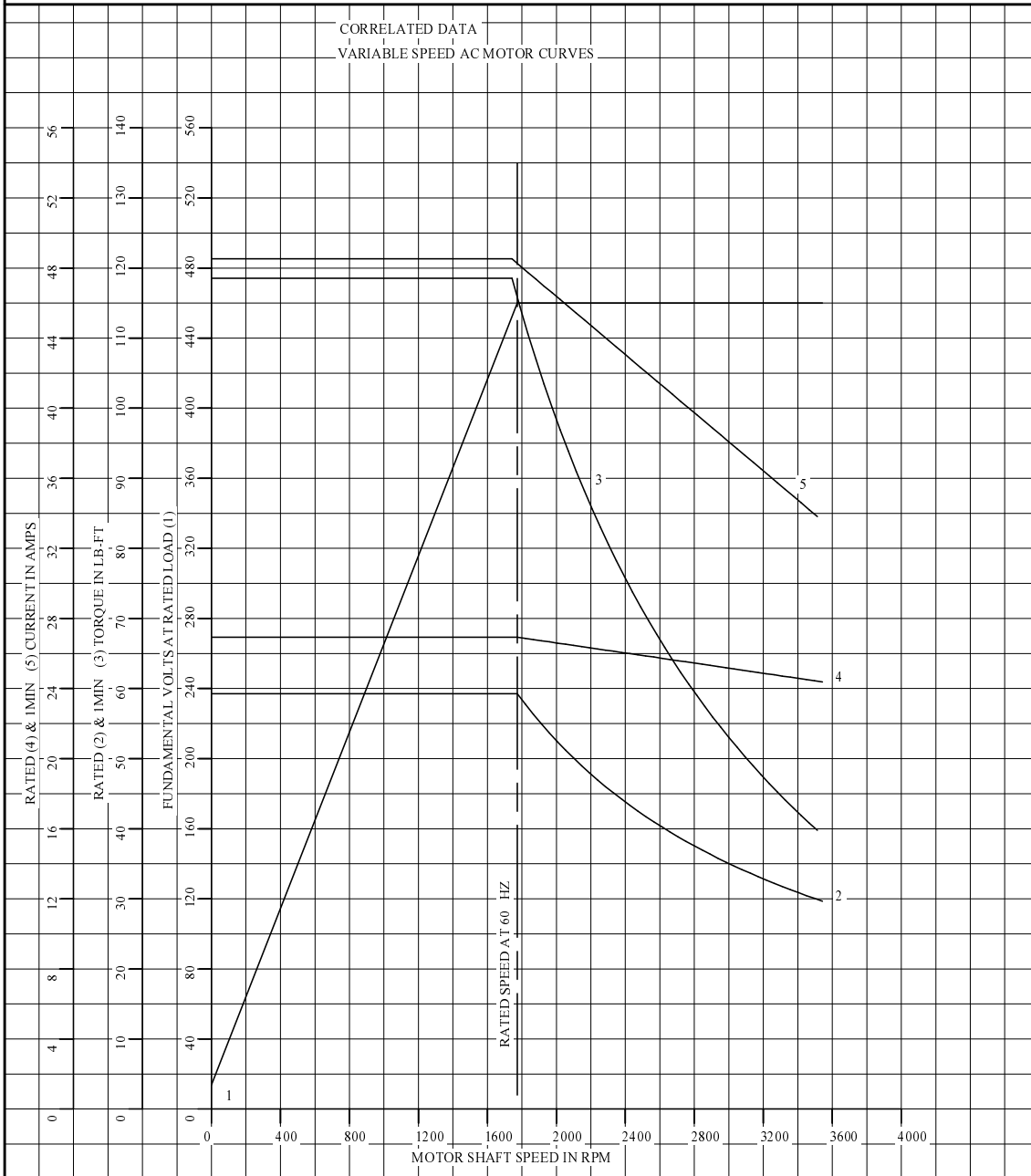

REMARKS: TYPICAL DATA
DATA VALID FOR NAMEPLATE SPEED RANGE ONLY

	DR. BY	B. GRANT	A-C MOTOR PERFORMANCE CURVES	L3308A SH 1 OF 2 ISSUE DATE 6-6-06
	CK. BY	B. GRANT		
	APP. BY	T. CUFR		
	DATE	6-6-06		

BALDOR • RELIANCE Part Information Packet: ZDFRPM21204C - 20HP, 1750RPM, 3PH, 60HZ, 2162C, TEFC, FOOT

REL S.O.	-	VOLTS	460	ENCLOSURE	TEFC	WYE CONN EQ CKT OHMS PER PHASE	
FRAME	FL2162	AMPS	27	MAX SAFE RPM	5000	(AT BASE RATING, 25 °C)	
HP	20	DUTY	CONT	IM (AMPS)	15	R1 .179	X1 .845
BASE SPEED	1775	S.F.	1.0	P.F.@NL/FL	.066/.777	R2 .122	X2 1.09
PHASE/HERTZ	3/60	AMB °C/INSUL	40/H	WK ² (Lb-Ft ²)	1.92	XM 18.1	

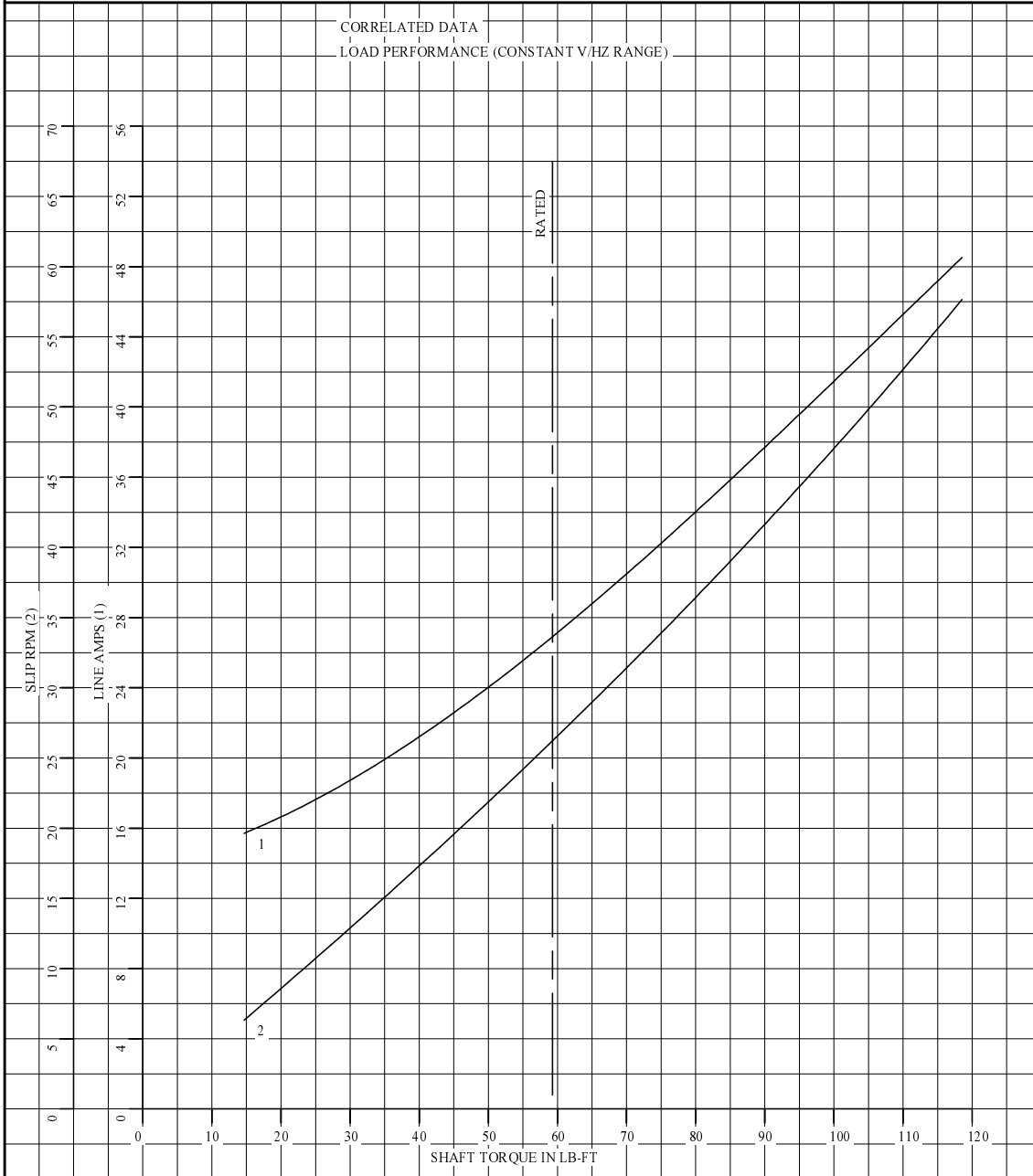

REMARKS: TYPICAL DATA DATA VALID FOR NAMEPLATE SPEED RANGE ONLY		DR. BY B. GRANT	A-C MOTOR PERFORMANCE CURVES	L3308A SH 2 OF 2 ISSUE DATE 6-6-06
		CK. BY B. GRANT		
		APP. BY T. CUFR		
		DATE 6-6-06		





RELIANCE ELECTRIC		RPM AC™ INVERTER DUTY MOTOR		
HP	RPM	AMPS	VOLTS	HZ
20	1760	27	460	
	3600	24	460	
				INSUL.

RPM™ AC MOTORS

RELIANCE 

BALDOR
BALDOR • DODGE • RELIANCE 



RPM AC VARIABLE SPEED MOTORS

POWER DENSITY

When space is at a premium, the RPM AC induction motor is the answer. RPM AC induction motors pack maximum torque into a small space. Available in totally enclosed and drip-proof guarded designs, the RPM AC motor can be up to three frame sizes smaller than the traditional NEMA or IEC motor. Leveraging our knowledge of variable speed DC motors the RPM AC motor combines square frame design, efficient cooling and premium insulation systems to prove ultimate torque performance in a compact package.

Features:

- Designed for optimized performance and longer life on adjustable frequency power
- Provides continuous constant torque down to zero speed in addition to high overload torque
- Custom designs for any base speed and extended top speeds using optimum pole technology
- Capable of handling the most demanding applications from 1/3 to 1000 HP

The laminated steel frame design in the 210 frame and larger offers the advantage of improved active material space utilization by replacing the common heavy cast iron frame with a rugged steel structure utilizing 100% of the active material. This is the same proven design technology that has been used in Reliance DC motors for generations.

RELIANCE 

OPTIMIZED VARIABLE SPEED PERFORMANCE

PRODUCT FEATURES

PLS – POSITIVE LUBRICATION BEARING SYSTEM

PLS – The Positive Lubrication System is a bearing lubrication system designed to provide complete bearing lubrication in any mounting position without over greasing or damaging the bearing. An exclusive and patented Reliance design, this premium lubrication system uses a combination of features that include two large open bearings, cast iron inner caps and directional grease channels that force fresh grease directly into the ball track to provide complete lubrication. The open bearing design eliminates the problems with shield bearings

caused by the collapse of the bearing shield resulting from high hydraulic pressure during regreasing. This fail safe design allows old grease to be easily purged from the bearing as fresh grease is directed into the bearing. The large grease reservoir created by the bracket and inner cap design assures ample grease is readily available between lubrication cycles. A key advantage of this open bearing design is that the bearings run cooler and prove longer bearing life. Smaller frame sizes feature a lube for life bearing design.

OPTIMUM POLE DESIGN

RPM AC motors are designed to utilize the best available winding designs for use on adjustable frequency power. By utilizing the best winding configuration (number of poles) the efficiency, power factor and current requirements can be optimized. Lower current draws resulting from the optimum pole design means that the adjustable frequency controller size can be minimized. The motor nameplate clearly defines the proper volts and frequency controller settings at base speed to assure proper motor performance.

PREMIUM ADJUSTABLE FREQUENCY INSULATION SYSTEM

It takes more than just good magnet wire to make a motor suitable for adjustable frequency power on today's high switching PWM wave form inverters. The insulation systems found in RPM AC motors are a combination of; high film copper magnet wire, high build resin varnish, slot and phase insulation, sleeving, extensive coil head ties and power lead materials all engineered to provide superior performance on

adjustable frequency power. These systems meet or exceed NEMA MG-1 part 31 for adjustable frequency power operation and have CIV (corona inception voltage) ratings above 1600 volts for 460 volt motors. Reliance Electric guarantees RPM AC motors corona free operation. This is your assurance of a trouble free, long life electrical system.

THERMAL PROTECTION AND NEC COMPLIANCE

All RPM AC motors are equipped with thermostats to provide thermal protection to the motor. When properly connected, this means that you are in full compliance with the 2005 NEC code requirements which requires thermal protection for motors operating on adjustable frequency power.

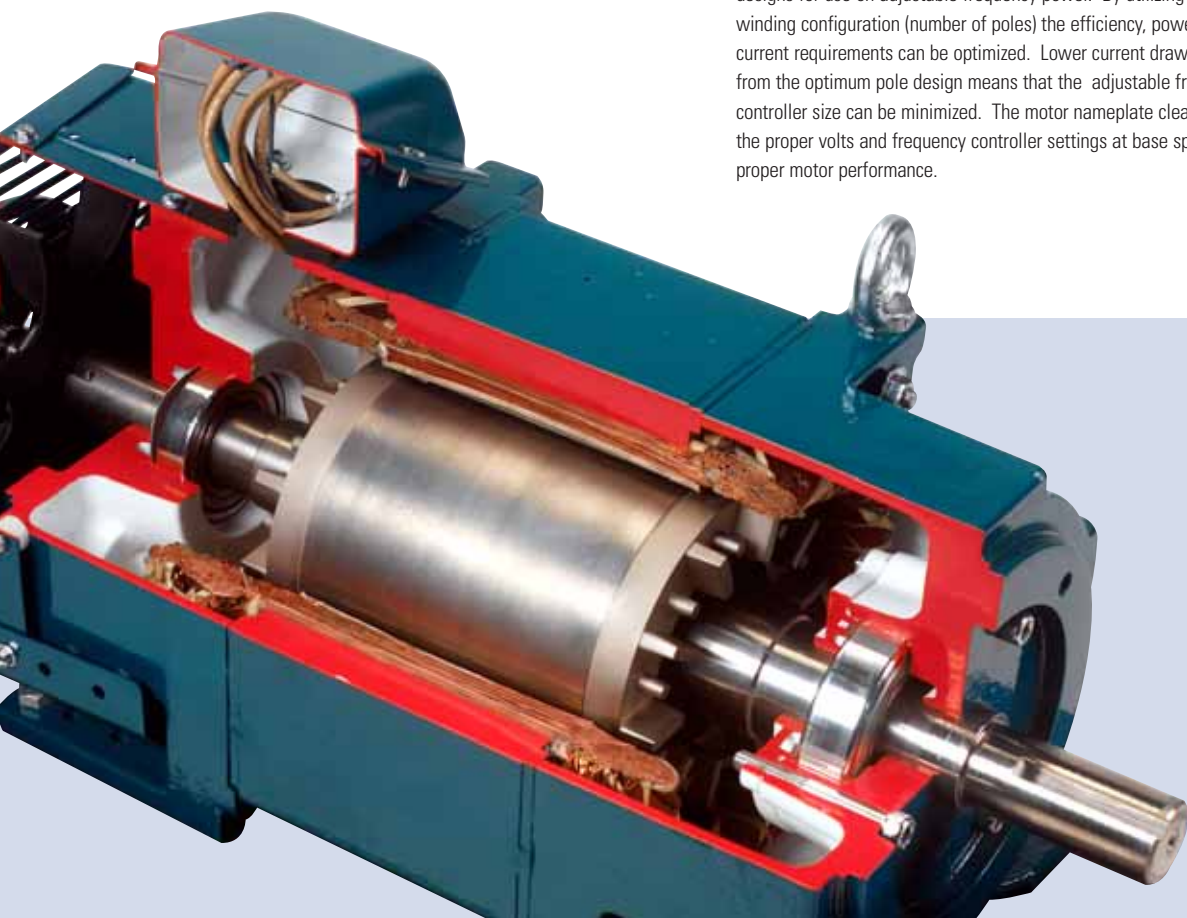

CCT – CONTINUOUS CONSTANT TORQUE TO ZERO SPEED

All RPM AC motors are designed to provide continuous constant torque from base speed down to and including zero speed. Unlike conventional sine wave motors, this means that at any speed below base speed, the RPM AC motor will generate full rated torque, run continuously and not over heat. Almost unbelievable - but true. Above base speed the RPM AC motor produces constant horsepower up to its' maximum speed capability.

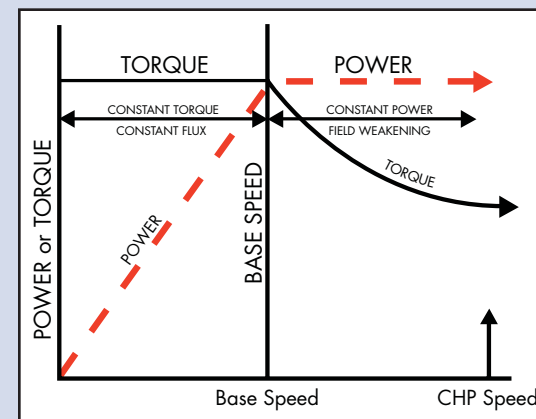

DRIP-PROOF GUARDED FORCE VENTILATED

DRIP-PROOF GUARDED FORCE VENTILATED

The RPM AC DPG-FV is the ultimate power dense machine. Utilizing laminated square frame technology, up to 1000 horsepower can be packed into a 440 frame. Commonly used in some of the most demanding industrial applications such as paper and converting, steel processing, extruders, traction, or oil well drilling, the RPM AC force ventilated design is the motor of choice.

FEATURES:

- The most compact and lowest weight design
- Continuous constant torque from zero speed to base speed (greater than 1000:1 turn down)
- 150% maximum overload torque from zero speed to base speed for 1 minute
- High torque to inertia ratio – up to 80% less inertia than the corresponding standard NEMA frame motor.
- Class H insulation standard on most ratings
- Surpasses NEMA MG-1 part 31 insulation system requirements for AF power
- PLS bearing system
- Encoder mounting provisions
- Thermal protection
- Insulated ODE bearing on 440 frames
- Numerous modifications available
- Top or side mount blower construction

DRIP-PROOF GUARDED FORCE VENTILATED

Industry	Application
Pulp & Paper, Converting	Winding and Unwinding
	Web process control
	DC conversions to AC
Petroleum, Chemical	Pump - process control
	Division 2
Drilling	Top Drive (high shock, high vibration, high peak torque, and extreme environmental conditions)
Metal	Winding and Unwinding
	Stamping press
Automotive & Aviation	Test stands
Plastic	Extrusion and injection molding

OPEN DRIP PROOF POWER DENSITY CHART (HP BY FRAME SIZE, 1800 RPM)

Horsepower	3	5	7.5	10	15	20	25	30	40	50	60	75	100	125	150	200	250	300	350	400	500	600	700	800	900	1000	
NEMA Std ODP	180		210	250	280	320	360	400	440																		
RPM AC DPFV			180			210		250	280	320	360	400															

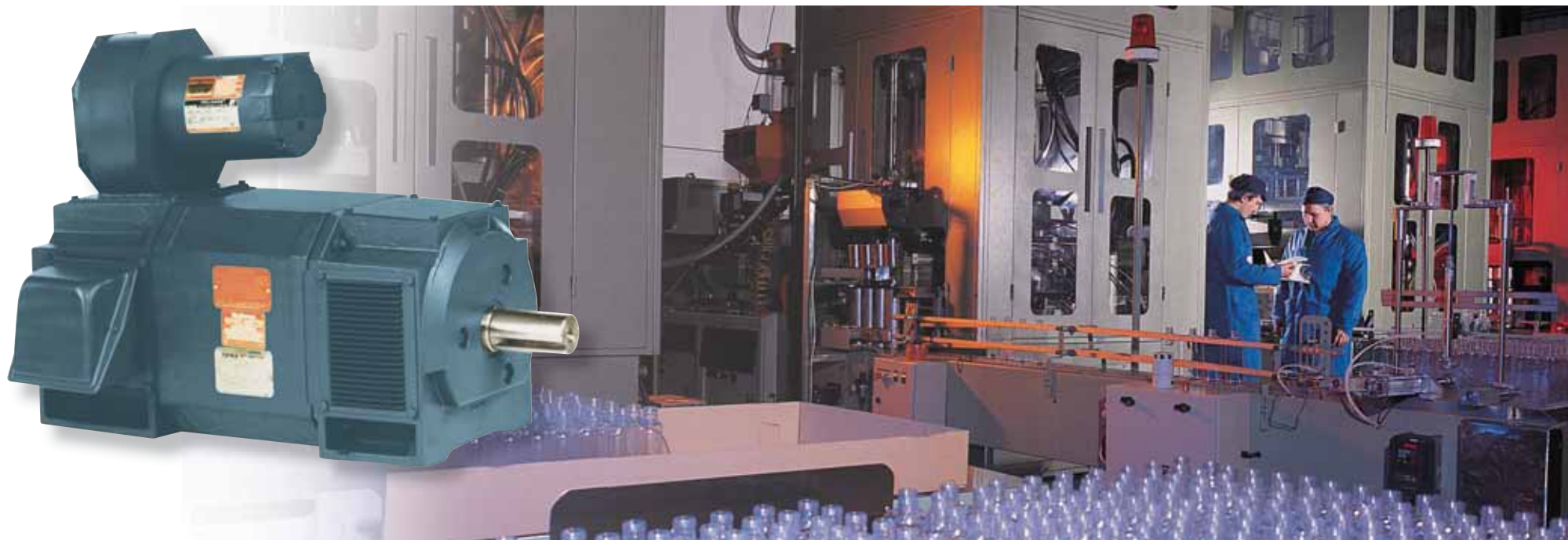

TOTALLY ENCLOSED

FAN COOLED AND BLOWER COOLED

For applications requiring totally enclosed protection, RPM AC motors are available in non-ventilated, fan cooled and in-line blower cooled construction. The totally enclosed family is designed with finned construction through the 250 frame to offer the industry's most efficient cooling and power density designs. The 210 and 250 laminated steel finned frame motors are an exclusive patent pending design offered only by Reliance Electric brand motors

Extra Tough – XT construction is available for outdoor, wash down, corrosive or harsh environments.

FEATURES:

- Small compact power density design
- Continuous constant torque from zero to base speed greater than 1000:1 turn down
- 200% maximum overload torque from zero speed to base speed for 1 minute
- 2:1 constant horsepower above base speed on most ratings
- Class H insulation standard on most ratings
- Surpasses NEMA MG-1 part 31 insulation system requirements for AF power
- PLS bearing system
- Available in full IEC metric construction
- Encoder mounting provisions
- Thermal protection
- Insulated ODE bearing on 440 frames
- Numerous modifications available
- Available pipe-in pipe-out for hazardous environments (IP23/IC17 or IP23/IC37)

TOTALLY ENCLOSED POWER DENSITY CHART (HP BY FRAME SIZE, 1800 RPM)

Horsepower	1/3	1	3	5	7.5	10	15	20	25	30	40	50	60	75	100	125	150	200	250	300	500	
NEMA Std TEFC	56	140	180	210	250	280	320	360	400													
RPM AC TENV/TEFC	56	140	180	210	250	280	320	360	400													
RPM AC TEBC				180	210	250	280	320	360	400	440											

TOTALLY ENCLOSED

Industry	Application
Pulp & Paper, Converting	Winding and Unwinding
	Spindles (TEBC)
	Web process control
	Power servo
	Conveyors
	DC conversions to AC
Petroleum, Chemical	Pump - process control
	Division 2
	Hazardous location (pipe in pipe out)
Metal	Winding and Unwinding
	Roll out table
	DC conversions to AC
Food	Pump - wash down
	High speed fan-drying
	Cutter knife (low inertia & high cyclic duty)
	Conveyors
	Food process equipment
Machine Tool	Spindles
Automotive	Traction (total electric and hybrid)
	Test stands
	Conveyors, pumps and fans

THE RPM AC WIZARD – DESIGN TOOL

You are no longer limited to conventional NEMA or IEC ratings. With the RPM AC Wizard tool, you design the motor that best satisfies your application requirements. You can select or input your unique horsepower, base speed, top speed, and overload requirements. With one click, the Wizard will design a motor that best fulfills your needs. The frame size and full load current rating are immediately defined. With another click, you get complete electrical design curves and performance data. Another click and you have a dimension sheet. The Wizard will even give you a couple of design options if a larger frame design could provide a lower full load current draw. Got an unusual duty cycle? No problem.

The Wizard can handle that too. This is a true motor design tool and not just a table look up program. You can design either NEMA or full IEC compliant motors. Get performance and dimensional data in standard or metric formats. Because the Wizard runs on your local PC, response is in seconds. To download your Wizard just go on line to www.reliance.com and select Motors/AC Motors/ Inverter Duty and click on the "Download the RPM AC Motor Wizard" next to RPM AC motors headline.



SPECIFIC APPLICATIONS

WIDE CONSTANT HORSEPOWER

Winder applications in paper mill and steel mill applications require a motor with a wide constant horsepower range capability. These RPM AC motors are designed for demanding horsepower requirements of both winding and unwind applications. Available enclosures include separately ventilated or blower cooled designs. These motors include many features to withstand the harsh conditions typically found in mill service. They are the ideal solution when converting from DC to AC power control

EXTRUDER DUTY

Designed to provide cool operating temperatures for extended motor life these motors meet Class B (80° C) temperature rise over the entire speed range from base speed, down to and including, zero speed. Shutdown and warning thermostats are standard. These motors are specifically designed for the high peak torque performance demands required by extruder duty applications. DPG-FV enclosure designs are available up to 700 HP.

DIVISION 2

RPM AC motors are designed for locations in areas classified by NEC for Class 1, Division 2 Groups A, B, C and D and also marked for Class 1, Zone 2 locations. Temperature code capabilities are offered from T1 through T3A. CSA certification is provided for both US and Canadian requirements. Enclosure options include TENV, TEFC, TEBC and DPG-FV.

HIGH SPEED

RPM AC motors are capable of high speeds due to their lower rotor inertias and high power density. The chart below depicts the current speed capability for the RPM AC product line by frame size.

RELIANCE

HIGH SPEED

Frame Size	IEC Frame	Maximum RPM Speed Capability
56	N/A	12,000
140	N/A	12,000
WE180 WF180	N/A	12,000
*FL180	*FDL112	11800
*FL210 RL210	*FDL130 DL130	8800 8800
*FL250 RL250	*FDL160 DL160	7900 7900
L280	DL180	6800
L320	DL200	5700
L360	DL225	5000
L400	DL250	4400
L440	DL280	3800

*Finned Frame Technology

IEC

IEC – TOTALLY ENCLOSED MOTORS “THE GLOBAL MOTOR SOLUTION”

RPM AC IEC motors are true metric designs. Mounting dimensions and electrical designs meet IEC global standards. All motor hardware is hard metric including bolts and conduit box connections. These motors are CE compliant and meet IEC standards for your high performance IEC applications. IEC flange mounting is also available.

FEATURES:

- IEC 34 and IEC 72 mechanical and electrical specifications
- CE compliant, ratings up to 725 KW
- IEC nameplate
- IEC terminal connection block
- Enclosures IP23, IP44 and IP55
- Continuous constant torque from zero speed to base speed (greater than 1000:1 turn down)
- 200% maximum overload torque from zero speed to base speed for 1 minute
- Class H insulation standard on most ratings
- Surpasses NEMA MG-1 part 31 insulation system requirements for AF power
- PLS bearing system
- Encoder mountings provisions
- Thermal protection
- Insulated ODE bearing on 440 frames
- Numerous modifications available including DIN flange, IEC brakes and encoders
- Top mounted conduit box mounting typical of most IEC specifications



www.baldor.com www.ptplace.com www.dodge-pt.com www.reliance.com



Baldor Electric Company Headquarters

P.O. Box 2400, Fort Smith, AR 72902-2400 U.S.A., Ph: (1) 479.648.5792, Fax (1) 479.648.5792, International Fax (1) 479.648.5895

Baldor - DODGE/Reliance

6040 Ponders Court, Greenville, SC 29615-4617 U.S.A., Ph: (1) 864.297.4800, FAX: (1) 864.281.2433

4/07 Copyright © 2007 Baldor Electric Company All Rights Reserved. Printed in USA.

This material is not intended to provide operational instructions. Appropriate instruction manuals and precautions should be studied prior to installation, operation or maintenance of equipment.